

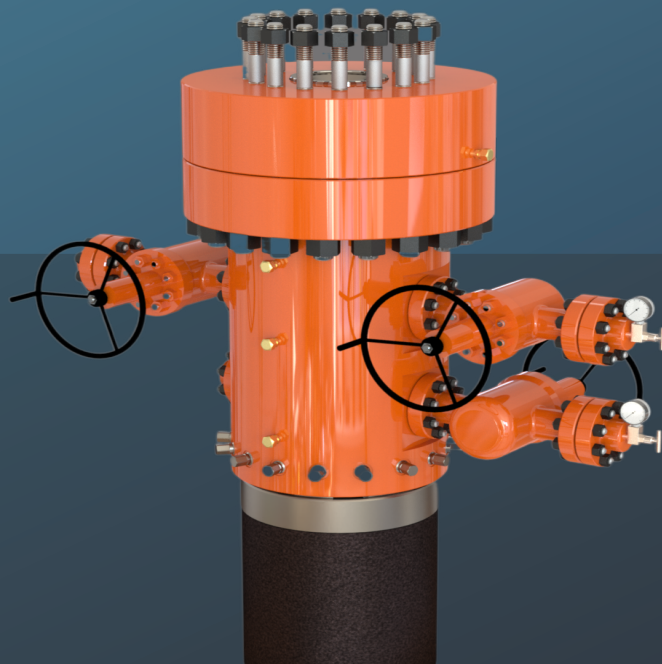

CERTIFICACIONES

# SINGLE-BODY WELLHEAD (SBW)<sup>TM</sup>



## KEY FEATURES

- Designed according to API Specification 6A to ensure product quality and performance.
- Improved pressure integrity: incorporating a Expanding Lock Ring that replaces the conventional Lock-Screws (Tie-down Screw), reducing leak paths and enhancing the performance and pressure integrity of the SBW<sup>TM</sup> using the minimum penetrations required.
- Seal technology: The SBW is equipped with industry leading elastomeric seals (S or FS profile), using the highest specifications to ensure pressure integrity.
- Innovative Design: per it's name, the SBW<sup>TM</sup> is made in a single wrought body material, reducing volume and dimensions compared with some Non-conventional Multistage Wellheads, suitable for reduced-size cellars.
- Fluted Design on Casing Hangers and Running Tools: this characteristic allows the fluid returns through the Diverter Drilling Riser or BOP Stack to the Flow Line, maximizing efficiency and operational flexibility, with safety and clean operations, friendly to the environment.
- Versatile Casing Hangers: Designed to Rotate and Reciprocate Casing Strings, providing greater adaptability to customer needs.
- Eliminates Cutting and Beveling operations on Casing pipes.
- Compatible with Slip-type Casing Hangers (in the event of contingency secondary operations).

## SAFETY

- It does not require hot work processes in Casing Pipes to Wellhead (Welding, Stress Relief).
- Minimizes the likelihood of work incidents/accidents associated with the use of striking hand tools, specially in reduced cellars, as it replaces standard connections.
- Reduces manual work in cellar, improving people's safety.
- Minimize open well exposure (Drilling and Completion operations through the Diverter Drilling Riser and the BOP Stack).
- Flange/Studded connectors and the use of Studs/Nuts (Wellhead vertical End Connectors) for all the Drilling Stages.

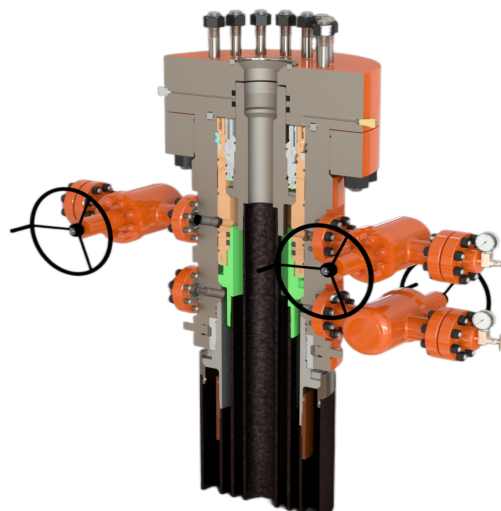

SBW<sup>TM</sup> 13.5/8" 10K,psi WP with 15K,psi Crossover Adapter Flange

The SBW<sup>TM</sup> is the result of our commitment to excellence, fusing the advantages of the Non-conventional Multistage Wellhead with the technologies of our successful RTSW<sup>TM</sup> Wellhead Family, getting a versatile product of unparalleled quality. The primary objective of this Wellhead is to reduce time in operations, improving the safety and efficiency.

## TIME SAVING

- Based on the premises of the Multistage Wellhead (Full Bore), which allows drilling and completion operations to be carried out with a single "BOP Stack" preventer assembly throughout the operation.
- Eliminates waiting time for cement setting in Casing String. (All Strings).
- Fast Connectors for Wellhead and BOP Stack assembly, which replaces the standard Flange-type Connectors, making simple, safety and efficient operations, without the need to rotate the product or assemble and tighten Flange Bolting.
- The Landing Hanger is assembled to the last joint of the Surface Casing string on the Rotary Table, and is lowered through the Drilling Riser, thereby reducing disassembly and installation times of the Wellhead.



**OIL PRODUCTS**  
WELL COMPLETIONS

**VATOLS**



**ARGENTINA**

+54 9 2994 729242

Ruta 151 - Km 31  
Barda del Medio  
Río Negro, Argentina

[gerenciacomercial@qroilproducts.com](mailto:gerenciacomercial@qroilproducts.com)

**ENGINEERING**  
**QUALITY**  
**INNOVATION**

Catálogo



**OIL PRODUCTS**  
WELL COMPLETIONS